

Rotary LIFT APPLICATION GUIDE



VEHICLE CLASS

GVW:
Gross Vehicle Weight



CLASS 1
Under 6,000 lbs. GVW



CLASS 2
6,001 to 10,000 lbs. GVW



CLASS 3
10,001 to 14,000 lbs. GVW



CLASS 4
14,001 to 16,000 lbs. GVW



CLASS 5
16,001 to 19,500 lbs. GVW



CLASS 6
19,501 to 26,000 lbs. GVW



CLASS 7
26,001 to 33,000 lbs. GVW



CLASS 8
33,001 lbs. and over GVW

	6,000 lbs.	7,000 lbs.	10,000 lbs.	8,000 lbs.	10,000 lbs.	12,000 lbs.	7,000 lbs.	10,000 lbs.	12,000 lbs.	15,000 lbs.	18,000 lbs.	12,000 lbs.	14,000 lbs.	18,000 lbs.	30,000 lbs.	40,000 lbs.	50,000 lbs.	60,000 lbs.	52,000 lbs.	72,000 lbs.	78,000 lbs.	108,000 lbs.	144,000 lbs.	30,000 lbs.	36,000 lbs.	45,000 lbs.	50,000 lbs.	75,000 lbs.	100,000 lbs.	60,000 lbs.	70,000 lbs.	90,000 lbs.	105,000 lbs.		
CLASS 1	•	•	•	•	•	•	•	•	•	•	•	•	•	•	•	•	•	•	•	•	•	•	•	•	•	•	•	•	•	•	•	•	•	•	
CLASS 2			•	•	•	•	•	•	•	•	•	•	•	•	•	•	•	•	•	•	•	•	•	•	•	•	•	•	•	•	•	•	•	•	•
CLASS 3							•	•	•	•	•	•	•	•	•	•	•	•	•	•	•	•	•	•	•	•	•	•	•	•	•	•	•	•	•
CLASS 4							•	•				•	•	•	•	•	•	•	•	•	•	•	•	•	•	•	•	•	•	•	•	•	•	•	•
CLASS 5							•					•	•	•	•	•	•	•	•	•	•	•	•	•	•	•	•	•	•	•	•	•	•	•	•
CLASS 6												•	•	•	•	•	•	•	•	•	•	•	•	•	•	•	•	•	•	•	•	•	•	•	•
CLASS 7												•	•	•	•	•	•	•	•	•	•	•	•	•	•	•	•	•	•	•	•	•	•	•	•
CLASS 8												•	•	•	•	•	•	•	•	•	•	•	•	•	•	•	•	•	•	•	•	•	•	•	•

NOTE: This reference guide indicates that the noted lift is applicable to the vehicle based on typical vehicle weights, lengths and wheelbases. All information should be verified before purchasing a lift.



Rotary World Headquarters
2700 Lanier Drive
Madison, IN 47250, USA



For more information and a complete guide to our product offering, visit us on the web at rotarylif.com or contact your local distributor today.

North America Contact Information

Sales: p 800.640.5438
f 800.578.5438
e userlink@rotarylif.com
Tech. Support: p 800.445.5438
e techlink@rotarylif.com



World Wide Contact Information

World Headquarters / USA: 1.812.273.1622
Canada: 1.905.812.9920
European Headquarters / Germany: +49.771.9233.0
United Kingdom: +44.178.747.7711
Australasia: +60.3.5192.5910
Latin America / Caribbean: 1.812.273.1622
Middle East / Northern Africa: +49.771.9233.0
Southern Africa: 1.812.273.1622
Brazil: +55.11.4534.1995

Sentinel Lock™ System (U.S. Patent No. 6,446,757)
YA12 True Up / Down Lifting Movement: (U.S. Patent No. 6,059,263)
Intuitive Control Console / Wireless Column Communication
HDC50/60 lifts are manufactured using the following patents:
(U.S. Patent No. 6983196 / U.S. Patent No. 8083034)



Available with SHOCKWAVE™



Drive-On

GENERAL SERVICE DRIVE-ON RUNWAY LIFTS

12,000 TO 60,000 LBS. CAPACITY



ROTARY LIFT

THE WORLD'S MOST TRUSTED LIFT

Lit# Rotary_Drive On Runway Brochure_2015.01
(Supersedes Lit# Rotary_Drive On Runway Brochure_2014.09)

©2015 VEHICLE SERVICE GROUP™, Printed in U.S.A., All Rights Reserved.
Unless otherwise indicated, ROTARY LIFT, VEHICLE SERVICE GROUP™, DOVER and all other trademarks are property of Dover Corporation and its affiliates.

Shown: SM14U100 14,000 lbs. capacity SHOCKWAVE-equipped runway lift with optional rolling jacks

www.rotarylif.com

WHAT COMES STANDARD WITH EVERY RUNWAY LIFT?

Versatility.

Nearly 30 years of experience goes into every drive-on lift we build. These runway lifts handle cars, vans and trucks with ease.



Functionality, space consideration and improved productivity are key components to consider when investing in a new lift. Our designers and engineers have taken all these considerations and used them to develop the most innovative, reliable and productive drive-on lift products on the market today.

Focus on Greater Productivity and More Workspace

Take advantage of the quick set-up for undercarriage repairs and wheel service. These versatile runway lifts are proven, durable and require little to no maintenance. **Plus with a new taller column**, technician's work under the highest runway rise in the industry allowing more service access.

Rotary Drive-On Lifts

Now Supercharged with SHOCKWAVE Equipped Power

Greater productivity means more profits and both can be achieved with Shockwave™. Optional Shockwave-equipped lifts are the fastest in the world helping you keep step with the ever-changing demand of the vehicle service industry.

Superior Design with Rigorous Cycle Testing

Rotary lifts are a great value because they are engineered to provide years of trouble-free service. Rotary maintains the largest in-house mechanical, electrical and controls engineering staff in the industry. State of the art design, modeling and analysis software ensures you get a well designed, long lasting product. **And now with an improved hydraulic and mechanical lifting system** concealed and protected under the runway, this high performance design generates greater durability and a more efficient and dependable lift operation.

Rotary cycle tests its lifts and components for at least 20,000 cycles at rated load, giving you a robust, proven and quality tested lift that won't let you down.

Local Service and Support

Our sales force attends intensive training on our products and the issues that face service repair facilities. Rotary representatives can help you evaluate which lift best meets your needs. With a world-wide network of highly-trained Rotary Authorized Installers and Distributors, service and parts support is always close at hand.

All from a partner you've trusted since 1925.

Rotary Lift.



SHOCKWAVE-EQUIPPED LIFTS FEATURE

2X Faster rise and descent than standard four-post lifts*



Patent pending DC power - Operates during loss of facility power



Spotline™ motion activated laser helps spot vehicles the first time



Center vehicles in the service bays quickly and accurately using this laser-guided system.

Wall or ceiling mounted laser

Rotary DESIGN ADVANTAGE

SHOCKWAVE Four-Post

PRODUCTIVITY & PERFORMANCE

1. PATENTED LOCKING SYSTEM
2. PATENT PENDING DC POWER - PROVIDES 2X FASTER SPEED
3. HIGHER RISE
4. INEXPENSIVE DAILY OPERATION
5. THIRD-PARTY ETL GOLD CERTIFIED

DELIVERING PRODUCTIVITY and PERFORMANCE

SUPERCHARGE YOUR LIFT WITH

SHOCKWAVE™



MAKE YOUR RUNWAY LIFT 2X FASTER

Mount power unit on front as shown or outside of front column

- ✓ Accelerate your productivity immediately!
- ✓ Increase your number of service orders per bay!
- ✓ Added productivity equals EXTRA PROFIT!



Shown: SM014U100 14,000 lbs. capacity SHOCKWAVE-equipped runway lift

The Industry Standard JUST GOT FASTER!

Shockwave's DC patent pending power system gives you lower cost and more reliable operation while using two standard Group 24 batteries.**

Shockwave's built in battery charger uses 110v power, eliminating the need for expensive 220v wiring resulting in an installation savings of 80% or more!

*Actual rise and descent times may vary depending on weight of the vehicle. **Batteries not included.

SHOCKWAVE IS AVAILABLE ON SM14 / SM014 SERIES OF LIFTS



Y12 12,000 LBS. CAPACITY DRIVE-ON LIFT

OPEN FRONT AND REAR WITH INNOVATIVE, INDUSTRY LEADING SPEED

Compared to traditional scissor lifts, technicians get to work sooner and with fewer obstructions to get in their way. Increase productivity and add dollars to your bottom line with speed, performance and reliability.

Productivity You Can Afford

The Y-Lift does so much more. From the smallest micro cars to the largest trucks, the Y-lift can handle up to a 189-1/2" wheelbase.

Faster than the Competition

An innovative weight sensing control system maximizes rise speed based on vehicle weight. Vehicles raise in 37 seconds* - at least 33% faster than comparable scissor lifts.

Y12 Features 360° Productivity

Yspace™ gives technicians 360° of vehicle access adding room to work faster and easier. Twice the access points for easy movement - front, rear and sides with side to side walk through for accessing multi-bay projects and tool boxes and making wheel alignment adjustments

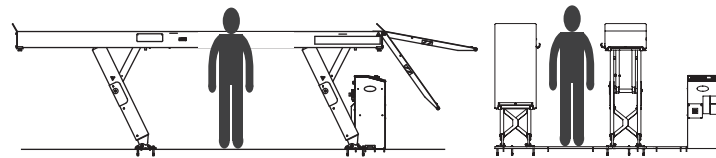

Twice the access points for easy technician movement

Y-Lift Patented Up and Down Movement provides true up/down lifting. There is no forward or rearward movement adding 20% more workspace below the lift and over 5 times more clear floor space under the runways.

Y-Lift Options:

- Can be flush mounted or recessed
- Extended ramps for lower profile vehicles (14" longer than standard)
- Swing jacks
- High efficiency LED TECH LIGHTS™



Y-Lift PRODUCTIVITY & PERFORMANCE

1. PATENTED TRUE UP / DOWN LIFTING
2. WEIGHT SENSOR CONTROL PROVIDES FASTER LIFTING SPEED
3. YSPACE™ ADDS 360° OF VEHICLE ACCESS
4. THIRD-PARTY ETL GOLD CERTIFIED

Y12 LIFT SPECIFICATIONS

Model:	Y12-L / Standard	Y12-EL1 / Extended
Max. Wheelbase	179 - 1/2" (4459mm)	189 - 1/2" (4813.3mm)
Rise	68 - 3/16" (1732mm)	68 - 3/16" (1732mm)
A. Length Overall	260" (6604mm)	270" (6858mm)
B. Width Overall	88" (2235mm)	88" (2235mm)
C. Length of Runways	202" (5131mm)	212" (5385mm)
D. Width of Runways	24" (610mm)	24" (610mm)
E. Height of Runways	11 - 3/16" (284mm)	11 - 3/16" (284mm)
F. Width Between Runways	40" (1016mm)	40" (1016mm)
Lifting Capacity	12,000 lbs. (5443kg)	12,000 lbs. (5443kg)
Motor / Power	2HP, 1Ø 208/230v	2 HP, 1Ø 208/230v
Time of Full Rise *	37 seconds	37 seconds
Lowering Time *	45 seconds	45 seconds
Min Bay Size	13' x 26'	13' x 26'

*Lower and rise speeds vary with voltage and vehicle weight.

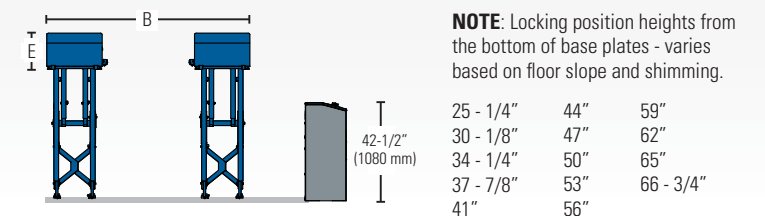

NOTE: Locking position heights from the bottom of base plates - varies based on floor slope and shimming.

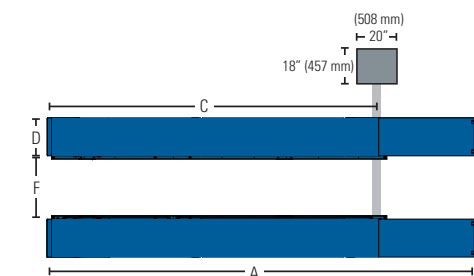

Y-Lifts are available in standard colors of blue, red, black and gray. Additional colors may be available - consult your Rotary® representative for details and pricing.



Front wheel stops can easily be replaced by optional drive through ramps

Low profile ramps checks with rollers provide smooth operation



No forward or rearward movement

Patented Up and Down Movement
The Y12 design provides true up/down lifting. There is no forward or rearward movement

Y-Lift can be flush mounted or recessed

Yspace™

360° vehicle access provides techs additional room to work faster and easier!

Hydraulic cylinder, locking mechanism and position sensor are mounted inside runway to protect them from corrosives and physical damage

SM14 14,000 LBS. CAPACITY FOUR-POST LIFT

NEW DRIVE-ON SERVICE LIFT WITH ADDED PRODUCTIVITY FEATURES

NEW SM14 Series drive-on lifts are engineered for commercial service, are ALI/ETL certified and exceed our industry exclusive performance durability cycle testing.

These 14K capacity lifts come standard with unmatched features, equipment and a array of productivity enhancing accessories. Three available wheelbases allow any shop to service a wide range of vehicles from cars to full size trucks. Bolster your service offerings and boost your bottom line with Rotary Lift, the most proven vehicle lifting name in the industry.

NEW Lift Features:

- Higher rise to over 78"** provides more work area under the vehicle
- Powder coated hammer tone paint finish** improves durability and paint life
- Louvered ramps with polymer rollers** provide improved traction and less floor gouging when driving on the lift
- Available with SHOCKWAVE** - creating 2X faster rise and descent
- EL model has more than **9 additional inches of wheelbase**

Available with **SHOCKWAVE™**



EXCLUSIVE PATENTED FEATURES

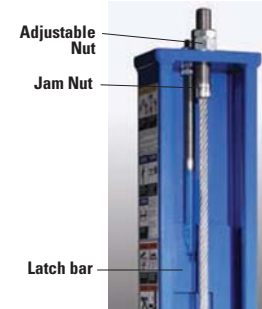

Patented dual function Sentinel Lock™ system features a slack cable guide arm that stays "on guard" to manage the lock latch. In a slack cable situation, the lock system kicks the lock into position. Fewer parts means less opportunity for service issues and more peace of mind.

Adjustable latch bars ensure the runways are level when resting on the latch bars at any of the multiple locking positions.



NEW improved hydraulic and mechanical lifting system design - concealed and protected under the runway, high performance cables and sheaves generate greater durability and a more efficient and dependable lift operation

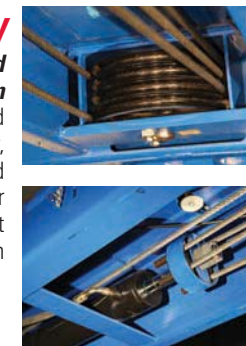

NEW 41" louvered ramps for improved drive-on traction. **Wheel chocks** automatically engage when lift is raised



Polymer rollers protect shop floor and adds a quieter operation

NEW powder coated hammer tone paint finish improves durability and paint life

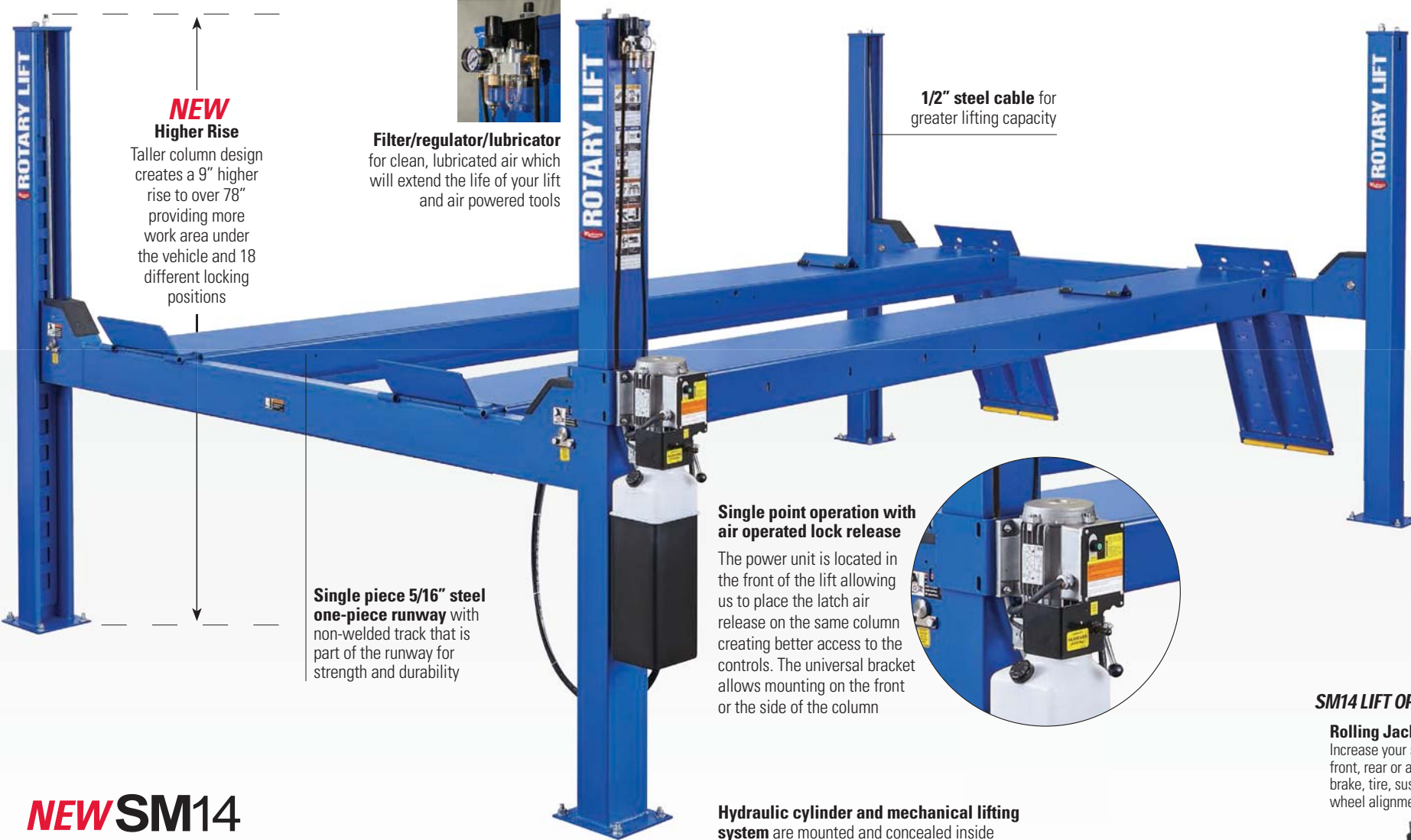

NEW Higher Rise

Taller column design creates a 9" higher rise to over 78" providing more work area under the vehicle and 18 different locking positions

Filter/regulator/lubricator for clean, lubricated air which will extend the life of your lift and air powered tools

1/2" steel cable for greater lifting capacity

Single piece 5/16" steel one-piece runway with non-welded track that is part of the runway for strength and durability

Single point operation with air operated lock release

The power unit is located in the front of the lift allowing us to place the latch air release on the same column creating better access to the controls. The universal bracket allows mounting on the front or the side of the column

Hydraulic cylinder and mechanical lifting system are mounted and concealed inside runway to protect them from corrosives and physical damage

SM14 LIFT OPTIONS

Rolling Jacks
Increase your service opportunities by lifting front, rear or all wheels off the runways for brake, tire, suspension and two or four-wheel alignment work



#RJ7000Y
7,000 lbs. capacity

Bolt-On Alignment Kits
Convert your general service four-post lift into an alignment lift that is compatible with the new technology 3-D alignment equipment on the market today. Comes with stainless steel turning radius gauges.

CONSULT FACTORY FOR OPTIONS

Rotary DESIGN ADVANTAGE

SM14 Four-Post PRODUCTIVITY & PERFORMANCE

1. PATENTED LOCKING SYSTEM
2. INDUSTRY-BEST RISE HEIGHT
3. SHOCKWAVE-EQUIPPED
4. THIRD-PARTY ETL GOLD CERTIFIED

SM14 LIFT SPECIFICATIONS

Model:	SM14 / Closed Front
Max. Wheelbase*	S 158" (4013mm) L 182" (4622mm) EL 215" (5461mm)
A. Rise / Floor to top of runway	78 3/4" (2000mm)
B. Length Overall†	S 18' 10" (5740mm) L 20' 10" (6350mm) EL 23' 7" (7188mm)
C. Width Overall**†	10' 11 3/4" (3346mm)
Runway Length	S 14' 7 1/4" (4451mm) L 16' 7 1/4" (5061mm) EL 19' 4" (5893mm)
D. Inside of Columns**	116 1/4" (2953mm)
E. Between Front and Rear Columns	S 171 1/4" (4349mm) L 195 1/4" (4959mm) EL 228 1/4" (5798mm)
F. Height of Columns	7' 6 1/2" (2299mm)
G. Width of Runways	20" (508mm)
H. Height of Runways	7" (178mm)
I. Width Between Runways	43" - 46" (1092-1168mm)
Lifting Capacity	14,000 lbs. (6350kg)
Motor / SHOCKWAVE	2 HP / 5 HP
Voltage Single Phase / SHOCKWAVE	208v-230v / 110V
Time of Full Rise	65 seconds
SHOCKWAVE Time of Full Rise and Descent***	35 seconds 18 seconds
Min. Bay Size	S 15' x 23' (4572 x 7010mm) L 15' x 26' (4572 x 7925mm) EL 15' x 28' (4572 x 8534mm)

S = Shorter length **L** = Standard length **EL** = Extended length

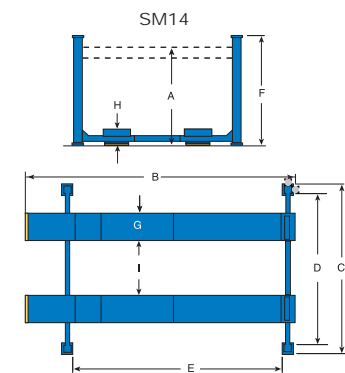

* Maximum wheelbase is based on a tire diameter of 29-1/2" (749mm)
** Narrow bay models available. Consult factory for min. bay size before ordering
*** Actual rise and descent times may vary depending on weight of the vehicle
† Length and / or width overall is 10 -1/2" longer with SHOCKWAVE power unit mounted on the side or front of column

SM14 lifts are available in blue and red. Black is available on the SM14L only.
RAL5005 RAL3002 RAL9005
Additional colors maybe available - consult your Rotary® representative for details and pricing.

NEW SM14 CLOSED FRONT DESIGN

Shown: SM14N100 14,000 lbs. capacity runway lift

SMO14 14,000 LBS. CAPACITY FOUR-POST LIFT

NEW DRIVE-ON SERVICE LIFT WITH ADDED PRODUCTIVITY FEATURES

NEW SMO14 OPEN FRONT drive-on lifts are engineered for commercial service, are ALI/ETL certified and exceed our industry exclusive performance durability cycle testing

Like the closed front SM14, the SMO14 comes standard with unmatched features, equipment and numerous productivity enhancing accessories. The **OPEN FRONT DESIGN** allows greater vehicle access and enhanced productivity. Three available wheelbases allow any shop to service a wide range of vehicles from cars to full size trucks.

NEW Lift Features:

Higher rise to over 78" provides more work area under the vehicle

Powder coated hammer tone paint finish improves durability and paint life

Louvered ramps with polymer rollers provide improved traction and less floor gouging when driving on the lift

Available with SHOCKWAVE - creating 2X faster rise and descent

EL model has more than **9 additional inches of wheelbase**

Available with **SHOCKWAVE™**



EXCLUSIVE PATENTED FEATURES

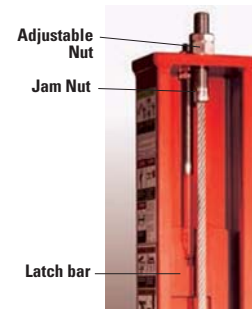

Patented dual function Sentinel Lock™ system features a slack cable guide arm that stays "on guard" to manage the lock latch. In a slack cable situation, the lock system kicks the lock into position. Fewer parts means less opportunity for service issues and more peace of mind.

Adjustable latch bars ensure the runways are level when resting on the latch bars at any of the multiple locking positions.



NEW improved hydraulic and mechanical lifting system design - concealed and protected under the runway, high performance cables and sheaves generate greater durability and a more efficient and dependable lift operation



NEW 41" louvered ramps for improved drive-on traction. **Wheel chocks** automatically engage when lift is raised

Polymer rollers protect shop floor and adds a quieter operation

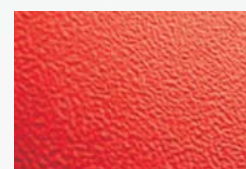

NEW powder coated hammer tone paint finish improves durability and paint life

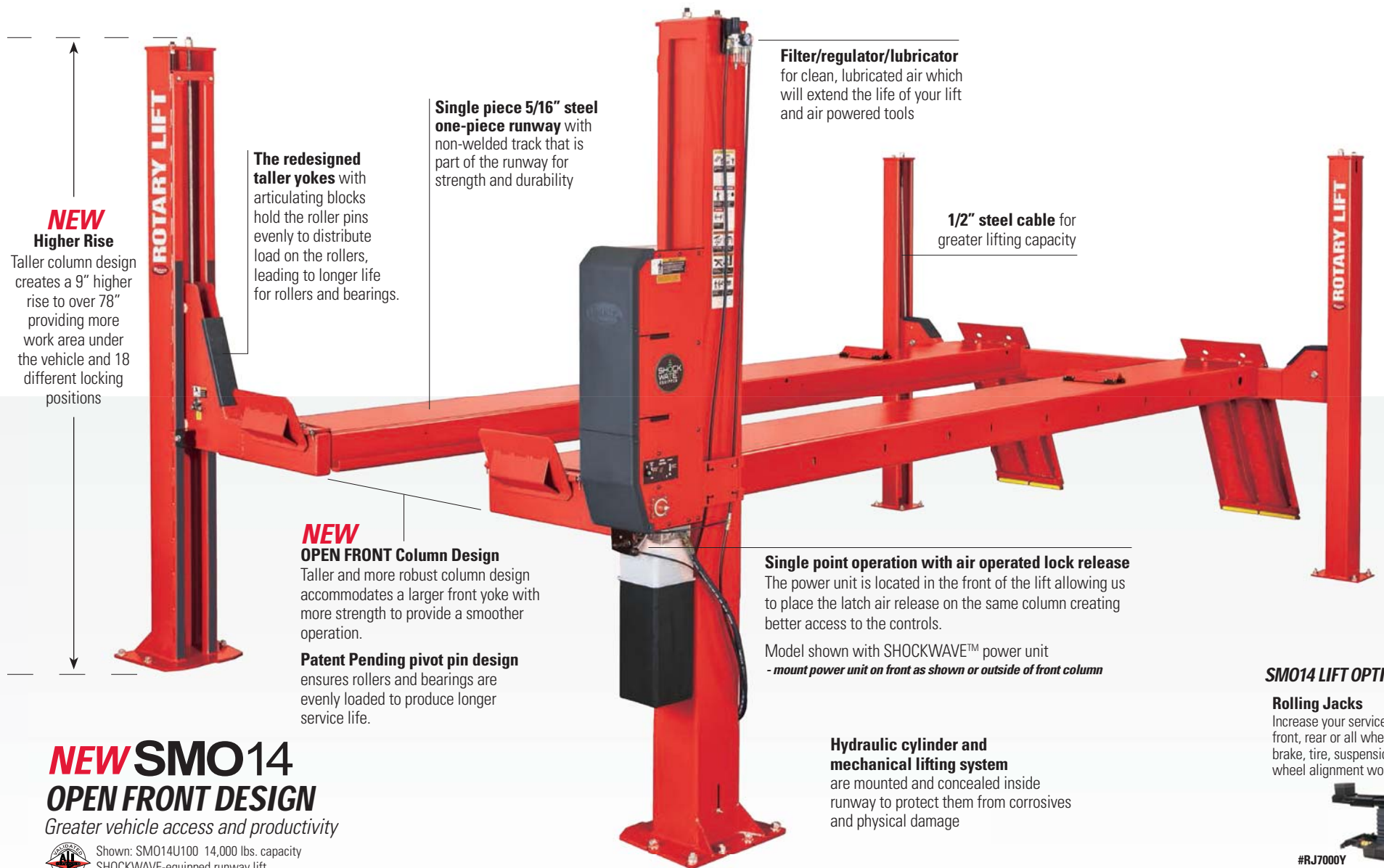

NEW Higher Rise
Taller column design creates a 9" higher rise to over 78" providing more work area under the vehicle and 18 different locking positions

The redesigned taller yokes with articulating blocks hold the roller pins evenly to distribute load on the rollers, leading to longer life for rollers and bearings.

Single piece 5/16" steel one-piece runway with non-welded track that is part of the runway for strength and durability

Filter/regulator/lubricator for clean, lubricated air which will extend the life of your lift and air powered tools

1/2" steel cable for greater lifting capacity

NEW OPEN FRONT Column Design
Taller and more robust column design accommodates a larger front yoke with more strength to provide a smoother operation.

Patent Pending pivot pin design ensures rollers and bearings are evenly loaded to produce longer service life.

Single point operation with air operated lock release
The power unit is located in the front of the lift allowing us to place the latch air release on the same column creating better access to the controls.

Model shown with SHOCKWAVE™ power unit
- mount power unit on front as shown or outside of front column

Hydraulic cylinder and mechanical lifting system are mounted and concealed inside runway to protect them from corrosives and physical damage

SMO14 LIFT OPTIONS

Rolling Jacks
Increase your service opportunities by lifting front, rear or all wheels off the runways for brake, tire, suspension and two or four-wheel alignment work



#RJ7000Y
7,000 lbs. capacity

Bolt-On Alignment Kits
Convert your general service four-post lift into an alignment lift that is compatible with the new technology 3-D alignment equipment on the market today. Comes with stainless steel turning radius gauges.

CONSULT FACTORY FOR OPTIONS

Rotary DESIGN ADVANTAGE

SMO14 Four-Post PRODUCTIVITY & PERFORMANCE

1. PATENTED LOCKING SYSTEM
2. INDUSTRY-BEST RISE HEIGHT
3. SHOCKWAVE-EQUIPPED
4. THIRD-PARTY ETL GOLD CERTIFIED

SMO14 LIFT SPECIFICATIONS

Model:	SMO14 / Open Front
Max. Wheelbase*	S 158" (4013mm) L 182" (4622mm) EL 215" (5461mm)
A. Rise / Floor to top of runway	78 3/4" (2000mm)
B. Length Overall†	S 19' 1" (5817mm) L 21' 1" (6426mm) EL 23' 10" (7264mm)
C. Width Overall†	11' 8 1/2" (3568mm)
Runway Length	S 14' 7 1/4" (4451mm) L 16' 7 1/4" (5061mm) EL 19' 4" (5893mm)
D. Inside of Columns	116 1/4" (2953mm)
E. Between Front and Rear Columns	S 170 3/4" (4337mm) L 194 3/4" (4946mm) EL 227 3/4" (5785mm)
F. Height of Columns	9' 1 1/16" (2770mm)
G. Width of Runways	20" (508mm)
H. Height of Runways	7" (178mm)
I. Width Between Runways	43" (1092mm)
Lifting Capacity	14,000 lbs. (6350kg)
Motor / SHOCKWAVE	2 HP / 5 HP
Voltage Single Phase / SHOCKWAVE	208v-230v / 110V
Time of Full Rise	65 seconds
SHOCKWAVE Time of Full Rise and Descent**	35 seconds 18 seconds
Min. Bay Size	S 15' x 23' (4572 x 7010mm) L 15' x 26' (4572 x 7925mm) EL 15' x 28' (4572 x 8534mm)

S = Shorter length L = Standard length EL = Extended length

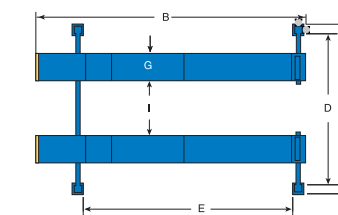
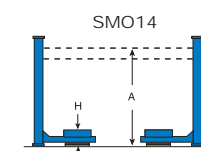

* Maximum wheelbase is based on a tire diameter of 29-1/2" (749mm)
** Actual rise and descent times may vary depending on weight of the vehicle
† Length and / or width overall is 10 -1/2" longer with SHOCKWAVE power unit mounted on the side or front of column

SMO14 lifts are available in blue and red.
RAL5005 RAL3002

Additional colors maybe available - consult your Rotary® representative for details and pricing.

NEW SMO14 OPEN FRONT DESIGN

Greater vehicle access and productivity

Shown: SMO14U100 14,000 lbs. capacity SHOCKWAVE-equipped runway lift

SM18 18,000 LBS. CAPACITY FOUR-POST LIFT

SERVICE CARS, VANS AND COMMERCIAL VEHICLES WITH EASE

When it comes to vehicle services, the versatile SM18 can handle a wheelbase range up to 230" and adding optional alignment equipment converts this lift to match today's alignment service systems.

18,000 lbs. capacity means more shop advantages

Take your shop services to the next level with this heavy-duty four-post lift. Designed without obstructions to vehicle access, technicians have room to move increasing productivity. This heavy-duty lift is big on performance without taking away signature Rotary lift features.

This lift is loaded with standard features you only expect to see with a Rotary drive-on lift.

Single point release air-locks save valuable working time by releasing all four spring loaded column locks with the push of a single lever.

The heavy-duty hydraulic cylinder and lift mechanism are located underneath the runway, eliminating damaging vehicle obstructions and prolonging the hydraulic system's lifespan.



Shown: SM18LO-X 18,000 lbs. capacity lift
Shown with optional alignment kit

EXCLUSIVE PATENTED FEATURES

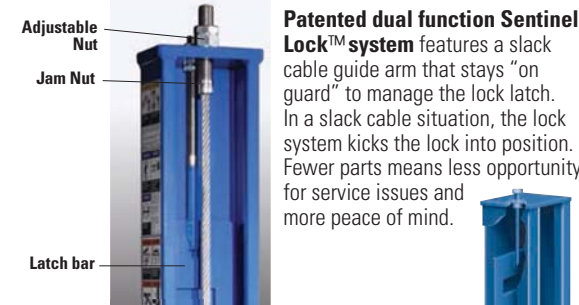

Patented dual function Sentinel Lock™ system features a slack cable guide arm that stays "on guard" to manage the lock latch. In a slack cable situation, the lock system kicks the lock into position. Fewer parts means less opportunity for service issues and more peace of mind.

Adjustable latch bars ensure the runways are level when resting on the latch bars at any of the multiple locking positions.



Shown: RJ9000

Optional rolling jacks with a variety of adapters lift front, rear or all wheels off the runways for brake, tire, alignment and suspension work. When idle, the jacks roll out of the way to provide unobstructed workspace between runways. Auxiliary axle adapters are standard.

Internal airline connections let two rolling jacks operate simultaneously.

Front wheel stops can easily be replaced by optional drive through ramps

Rotary DESIGN ADVANTAGE

SM18 Four-Post

PRODUCTIVITY & PERFORMANCE

1. PATENTED LOCKING SYSTEM
2. ALIGNMENT CONVERSION AVAILABLE
3. ADJUSTABLE RUNWAY COMPONENTS
4. THIRD-PARTY ETL GOLD CERTIFIED

SM18 LIFT SPECIFICATIONS

Model:	SM18	SM18-EL
Max. Wheelbase	194" (4927mm)	230" (5842mm)
A. Rise / Floor to top of runway	68" (1727mm)	68" (1727mm)
B. Length Overall*	22' 11" (6990mm)	25' 11" (7904mm)
C. Width Overall	137 11/16" (3497mm)	137 11/16" (3497mm)
D. Inside of Columns	122 3/16" (3104mm)	122 3/16" (3104mm)
E. Between Columns	212" (5385mm)	248" (6299mm)
F. Column Height	6' 5 3/4" (1975mm)	6' 5 3/4" (1975mm)
G. Width of Runways	22" (559mm)	22" (559mm)
H. Height of Runways	8 5/16" (211mm)	8 5/16" (211mm)
I. Width Between Runways	43" (1092mm)	43" (1092mm)
Min. / Max	46" (1168mm)	46" (1168mm)
Lifting Capacity	18,000 lbs. (8165kg)	18,000 lbs. (8165kg)
Motor / Power **	2HP, 1Ø 208/230v	2 HP, 1Ø 208/230v
Time of Full Rise †	80 seconds	80 seconds
Lowering Time	25 seconds	25 seconds
Min Bay Size	13' x 27' (3962mm x 8230mm)	13' x 27' (3962mm x 8230mm)

* With standard length ramps
** Optional 3-phase electrical available
† At full capacity

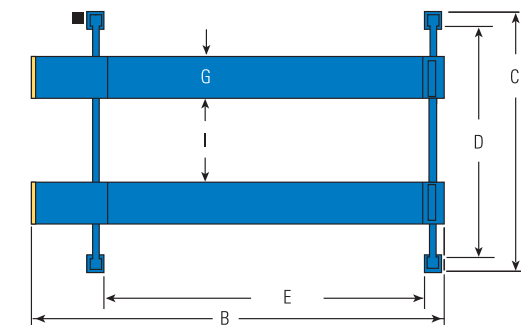
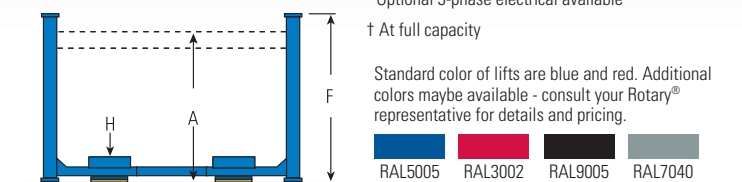

Automatic ramp chocks engage when the lift is raised. Clearance holes allow the ramp chocks to clear runway bolts with less noise on vehicle approach.



Filter/regulator/lubricator for clean, lubricated air which will extend the life of your lift and air powered tools

1/2" steel cable for greater lifting capacity and durability

Protective strips on ramp ends reduce noise and eliminate floor gouging.

Removable work step Standard on the SM18, this repositionable stand fits the outer sides of the four-post runway slots as shown.



Model # FC5663BK

Single piece non-welded runway with tracks for rolling jacks

Transform your existing flat top SM18 runway lift into a fully functioning alignment lift.



The kit fastens to the side of the lift runway and features adjustable flush mounted components that accommodate a variety of vehicle wheelbases.

SM18 Alignment Kit
Part No. S100126

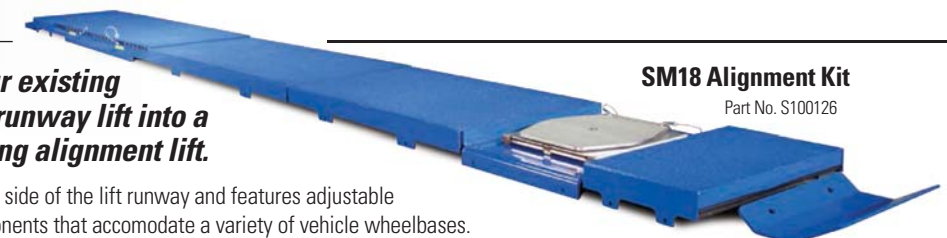

SM30 30,000 LBS. CAPACITY RUNWAY LIFT

SERVICE A VARIETY OF VEHICLES WITH MAXIMUM PRODUCTIVITY

Heavy-Duty 30K Four Post Drive-On Lifts - Service Wheelbases Up To 235"

Take heavy duty lift service to the next level with this four-post designed without side obstructions and better vehicle access. With a 68" lifting height, the SM30 clear floor design allows technicians room to access tool boxes and other shop equipment increasing productivity and reducing downtime. Plus, the single point air-lock release releases all four spring loaded column locks at one time adding greater productivity. Numerous accessories turns this lift into a complete service solution for any shops' needs. These lifts handle cars, vans, trucks - even light and medium duty commercial vehicles with ease. If you service a wide variety of vehicles, Rotary 30,000 lbs. capacity four-post auto lifts are the right choice for maximum productivity.

EXCLUSIVE PATENTED FEATURES

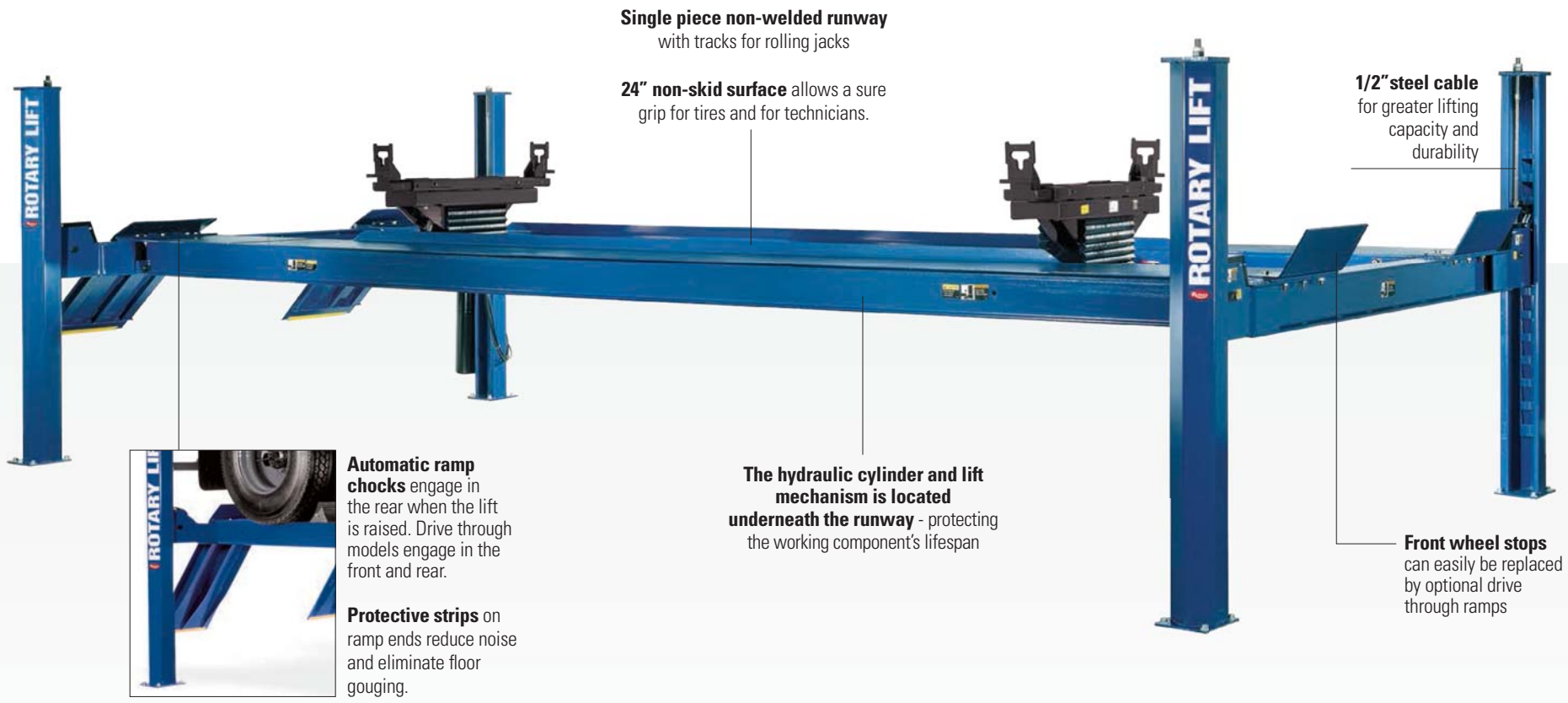
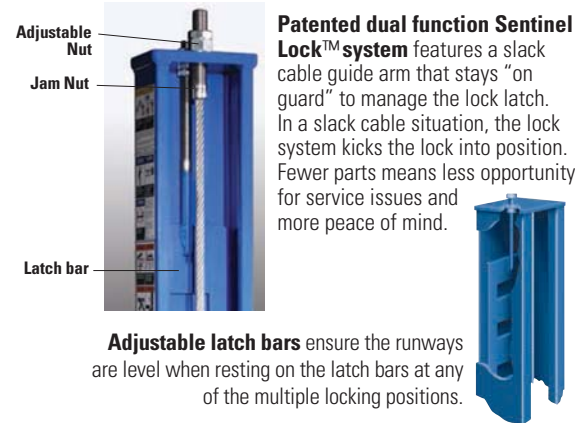

Optional rolling jacks with a variety of adapters lift front, rear or all wheels off the runways for brake, tire, alignment and suspension work. When idle, the jacks roll out of the way to provide unobstructed workspace between runways. Auxiliary axle adapters are standard.

Standard Internal airline connections let two rolling jacks operate simultaneously.

Lube work is made easy when a **rolling drain pan** with splashguard, drain valve and dust cap is added. An eight foot drain hose with a quick disconnect fitting is also available.



Rotary DESIGN ADVANTAGE

SM30 Four-Post PRODUCTIVITY & PERFORMANCE

1. PATENTED SENTINEL LOCKING SYSTEM
2. MULTIPLE RUNWAY LENGTHS
3. ADJUSTABLE RUNWAY WIDTHS
4. THIRD-PARTY ETL GOLD CERTIFIED

SM30 LIFT SPECIFICATIONS

Model:	SM30S SM30L SM30EL
Maximum Wheelbase*	S 235" (5969mm) L 271" (6883mm) EL 307" (7798mm)
A. Rise / Floor to top of runway	68" (1727mm)
B. Length Overall	S 25' 8 1/8" (7826mm) L 28' 8 1/8" (8741mm) EL 31' 8 1/8" (9655mm)
C. Width Overall	12' 4 13/16" (3780mm)
D. Inside of Columns	133" (3378mm)
E. Between Columns	S 249" (6325mm) L 285" (7239mm) EL 321" (8153mm)
F. Height of Columns	7' 3/4" (2153mm)
G. Width of Runways	24" (610mm)
H. Height of Runways	8 3/4" (222mm)
I. Width Between Runways (min.)	42" (1067mm)
J. Width Between Runways (max.)	48" (1219mm)
K. Length of Runways	S 248 1/2" (6312mm) L 284 1/2" (7226mm) EL 320 1/2" (8141mm)
Lifting Capacity	30,000 lbs. (13608kg)
Motor	4 HP
Voltage Single Phase	208v-230v
Time of Full Rise	105 seconds
Min. Bay Size	S 16' x 30' (4877 x 9144mm) L 16' x 33' (4877 x 10059mm) EL 16' x 36' (4577 x 10973mm)

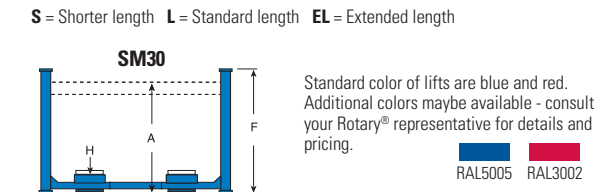

Shown: SM30ND-X
30,000 lbs. capacity with optional rolling jacks

40000HDL

40,000 LBS. CAPACITY RUNWAY LIFT

Heavy-Duty 40K Four Post Drive-On Lift

The 40000HDL runway lift is the powerful and reliable lifting system for even the largest vehicles from RVs to commercial trucks. The fully adjustable runways accommodate a variety of wheelbase widths and with a 65" rise height, even a lift with this capacity provides a generous amount of headroom for technicians. Increase service capacity with optional rolling jacks and internal air line. Add drive-thru ramps to provide a quick and easy on-off operation.

Whatever the job, this heavy duty four post was built to lift it!



Shown: 40000HDL
40,000 lbs. capacity

Service a wide range of vehicles with a heavy duty Rotary 40,000HDL four-post lift

Proven and durable, this lift is loaded with heavy duty features and options you only expect to see with a Rotary drive-on lift.

Single point release air-locks save valuable working time by releasing all four spring loaded column locks with the push of a single lever.

Two heavy-duty hydraulic cylinders and motors create the required power and stability to lift the largest vehicles.

Adjustable runway widths from 40' to 82" accommodate a variety of wheelbases.

Add optional rolling bridge jacks and increase your service opportunities by lifting wheels off the runways for two-wheel alignment work.



Shown: RJ150BK



40000HDL Four-Post

PRODUCTIVITY & PERFORMANCE

1. SINGLE POINT RELEASE AIR LOCKS
2. ADJUSTABLE RUNWAY WIDTHS
3. SURFACE OR RECESSED INSTALLATION
4. CONVERTS TO ALIGNMENT LIFT

40,000HDL LIFT SPECIFICATIONS

Model:	40000HDL
Maximum Wheelbase	25' (7620mm)
A. Rise / Floor to top of runway	65" (1651mm)
B. Length Overall	33' 10" (10312mm)
C. Width Overall	14' 3" (4343mm)
D. Inside of Columns	11' 10" (3607mm)
E. Between Columns	24' 3" (7391mm)
F. Height of Columns	12' 10" (3912mm)
G. Width of Runways	24" (610mm)
H. Height of Runways	9" (229mm)
I. Minimum Width Between Runways	40" (1016mm)
I. Maximum Width Between Runways	82" (2083mm)
J. Length of Runways	27' 6" (8382mm)
Lifting Capacity	40,000 lbs. (18140kg)
Motor	4 HP x 2
Voltage Three Phase †	208v-230v / 460v
Time of Full Rise	100 seconds
Min. Bay Size	18' x 38' (5486mm x 11582mm)

Safety latches in each leg for maximum lifting security

Heavy-duty chains ensure runways are level throughout the lifting process

I-Beam construction in runways for maximum capacity

Fully adjustable runway track width to accommodate any vehicle

24" non-skid surface allows a sure grip for tires and technicians

Front wheel stops can easily be replaced with optional drive-thru ramps

Two 2-HP motors and two cylinders provide the stability and tremendous lifting power required for the largest vehicles

40000 HDL can be surface mounted or recessed

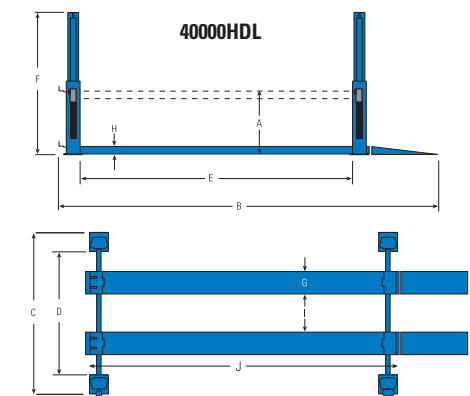

† Optional single phase electrical available.

Standard color of lifts are blue and red. Additional colors maybe available - consult your Rotary® representative for details and pricing.



Shown: 40000HDL 40,000 lbs. capacity drive-on lift

HDC50/60 HEAVY-DUTY RUNWAY LIFT

THE MOST VERSATILE AND FASTEST FOUR-POST LIFT IN THE INDUSTRY

Operator friendly designs and industry exclusive features offer you a drive-on four post lift that's easier to use and faster than similar competitive lifts.

LOWER YOUR COST OF OWNERSHIP

With no complicated or expensive electrical installation, no cables, chains or sheaves to maintain and fewer moving parts, the fully hydraulic HDC50/60 is one of the most dynamic four-post lifts in the industry! DC battery operated with an onboard charger that needs only 110v electricity to charge, this affordable four post lift is easy to operate and inexpensive to own. Choose the lift model that fits your needs best - both model lengths are available in both lifting capacities!

ENVIRONMENTALLY FRIENDLY FEATURES

Surface mounted and anchored, it requires no excavation or site preparation

Optional high efficiency LED lighting saves electricity and money over comparable incandescent and fluorescent lighting

Bio fluid ready

DESIGN FEATURES

28" wide runways with two available lengths and capacities handle any number of vehicles from cars to the largest trucks

Clear floor four-post design creates an open work area free of interference

Industry best rise time of 65 seconds

78" lifting height benefits the tallest techs

Standard internal airline connections let two rolling jacks operate simultaneously and provides outlets for air tools



PATENTED CONTROL SYSTEM

Operate lift from ANY post with this user-friendly, exclusive control system

Position memory - lifting cycles are configured and set creating a two step process: turn each column on, lock the columns and go!

- Programmable controls show operational status for each column plus, program a height limiter - maintains level within 3"
- Real time height reading
- Battery Indicator
- E-Stop button located at each panel
- Audible descent alarm

BATTERY OPERATED LIFT WITH ON-BOARD CHARGER

- Generates faster lift cycle times - *at least 1.5 X faster than comparable lifts*
- No special AC wiring costs or requirements
- Low electrical usage - *DC battery power* and 110V charging*
- Fully functional when the power goes out

* Battery purchased separately for international use

THIRD PARTY CERTIFIED

The HCD Series lift meets the ANSI/ALI ALCTV 2011 standard, including the required third-party validation. Your assurance of certification is the gold ALI/ETL certified label.



HORSESHOE WIRING

The HDC is connected by three communication cables, (forming a horseshoe) protected within the lift runways.

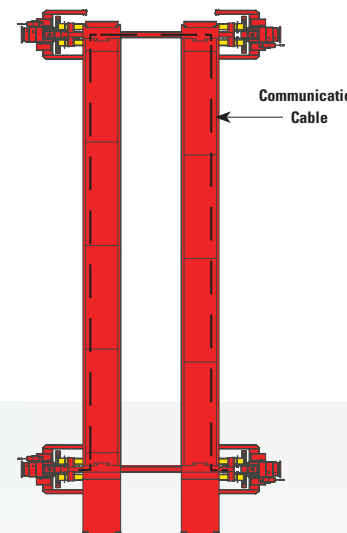

INVERTED HYDRAULIC CYLINDER

The hydraulic cylinder is inverted inside the carriage so the chrome piston rod is protected from debris and damage - extending the life of the column and reducing maintenance frequency and cost

WHEEL CHOCKS

Automatic wheel chocks engage when the lift is raised and ramps are off the floor

ANCHORED COLUMN SUPPORT

Four easy to install wedge style anchors secure each heavy duty column to the floor

LOW DRIVE-ON HEIGHT

Ramps and runways accommodate a variety of vehicle types. Optional drive thru ramp kit available.

Rotary DESIGN ADVANTAGE

HDC Four-Post PRODUCTIVITY & PERFORMANCE

1. PATENTED CONTROL PANEL
2. DC POWER - PROVIDES SPEED
3. INVERTED HYDRAULIC CYLINDER
4. THIRD-PARTY ETL GOLD CERTIFIED

HDC 50 / 60 LIFT SPECIFICATIONS*

Model:	HDC50	HDC60
Lifting Capacity	50,000 lbs. (22679kg)	60,000 lbs. (27215kg)
Maximum Wheelbase	28' (336" / 8534mm)	33' (396" / 10058mm)
Max. Rise / Floor to top of runway	78" (1981mm)	78" (1981mm)
A. Length Overall	35' 7-1/2" (10858mm)	40' 7-1/2" (12382mm)
B. Width Overall - outside controls	15' 11" (4851mm)	15' 11" (4851mm)
Height of Columns when raised	144 - 3/4" (3677mm)	144 - 3/4" (3677mm)
C. Width of Runways	28" (711mm)	28" (711mm)
D. Drive Thru Between Columns	11'-10" (3607mm)	11'-10" (3607mm)
E. Runway Spacing	45" (1143mm)	45" (1143mm)
Rise Time	65 seconds	65 seconds
Ramp Angle	10 degrees	10 degrees
Power Usage	Battery powered Charges on 110V	Battery powered Charges on 110V

***BOTH 28' AND 33' RUNWAY LENGTH MODELS ARE AVAILABLE AS 50,000 AND 60,000 LBS. CAPACITY LIFTS**

Standard color of HDC50 / 60 lifts are red. Additional colors may be available - consult your Rotary® representative for details and pricing.

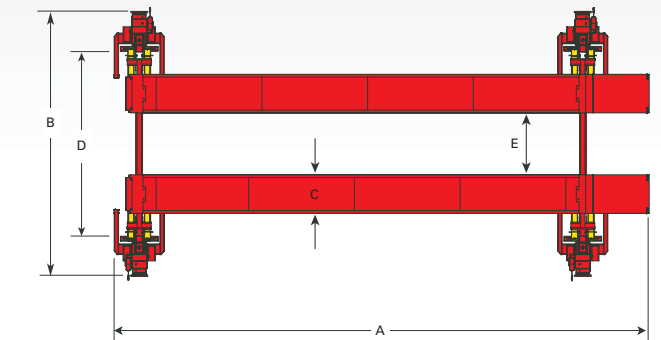

Shown: HDC60U000
60,000 lbs. capacity four-post lift



Shown: HDC60U000
60,000 lbs. capacity four-post lift



OPTIONAL LIFT ACCESSORIES

Increase bay productivity with these drive-on lift accessories

TECH LIGHT™ LED Lighting Kit

Attach the four light wands to runways for effective, efficient lighting where you need it.

- 120V AC input voltage
- 60hz



#FA5700 Lighting unit includes 60W power supply unit, 8mm cable and suspensions

Air / Utility Box

Mounts easily on any column and provides quick access to utilities

- Two 110v electric outlets and air connection
- The filter/regulator/lubricator helps extend the life of your air tools



#FA915 KIT

Oil Drain Pan

Available for most lifts, drain pan includes splash guard, drain valve and dust cap.

CONSULT FACTORY FOR OPTIONS



#FC5663BK

Removable Work Steps

Fits 14K and 18K four-post lifts with slots on sides of runways as shown.



Internal Airline Kit

Standard Internal airline connections let two rolling jacks operate simultaneously, and provides air outlet on the runway.



#FC5760-14

Swing Air Jacks

6,000 lbs. and 8,000 lbs. capacity swing air jacks pivot and lay flat between the runways when not in use.



#SJ6000 and #SJ8000 Y12 / SM14 / SM014 accessory

Rolling Jacks

Increase your service opportunities by lifting front, rear or all wheels off the runways for brake, tire, suspension and two or four-wheel alignment work. Available in 6,000 lbs. to 25,000 lbs. capacities.

- Hydraulic operation with 2 locking positions
- Drop in rubber adapters made with high durometer rubber.
- Easy glide wheels roll smoothly in the track. A sweeper pushes debris away from the wheel.



#RJ6000Y Y12 accessory

#RJ7000Y SM14 / SM014 accessory

#RJ9000Y-1BK / #RJ9000Y-2BK SM18 / SM30 accessory

#RJ150BK SM30 / 4000HDL accessory

HDC50/60 HEAVY DUTY LIFT ACCESSORIES

25,000 lbs. Capacity Rolling Jack

25K rolling bridge can be attached to the runway to create various lifting options to make it even more versatile.



#RJ25001L

LED Lighting

High-efficiency LED lighting, single touch operation system provides hands-free lighting under the vehicle from the lift's control panel.



#M140002

Bolt-On Alignment Kits

Convert your general service four-post lift into an alignment lift that is compatible with the new technology 3-D alignment equipment on the market today. Comes with stainless steel turning radius gauges.

CONSULT FACTORY FOR OPTIONS



Ramp Kits

Allows for drive-thru capability

- Oil resistant, non-skid coating
- Includes two ramps and hardware
- Extended length ramps for low clearance vehicles available

CONSULT FACTORY FOR OPTIONS



#M140111

Mobility Kit

Optional wheel kit is available to provide portability for each column adding movement within your shop.

Drive-Thru Ramp Kit

Adding a drive-thru ramp kit creates a quick and easy on-off service operation for service bays.



#APRAMP10DTKIT 10' (3048mm) drive-thru ramp kit

Drive-On Standard/Optional Lift Features

FEATURE	Standard Feature ● Optional Feature ○	Y12 12,000 lbs.	SM14 14,000 lbs.	SM014 14,000 lbs.	SM18 18,000 lbs.
ALI Certified		●	●	●	●
Open front or open rear design		Open front and rear	Closed front	Open front	Closed front
Recessed installation		○	N/A	N/A	N/A
SHOCKWAVE™ Equipped models		N/A	○	○	N/A
Power unit on front column		N/A	●	●	●
Single point lock release		●	●	●	●
Cylinder located under the runway		●	●	●	●
Dual function Sentinel Lock™ System		N/A	●	●	●
Air filter / regulator / lubricator		●	●	●	●
Air / Electric utility box		○	○	○	○
Multiple runway lengths available		○	○	○	○
Adjustable runway widths		N/A	○	N/A	○
Adjustable locking latch bars		N/A	●	●	●
One piece runway		●	●	●	●
Internal airline kit		○	○	○	●
Rolling jacks available		○	○	○	○
Converts to alignment lift		N/A	○	○	○
Drive-thru conversion		○	○	○	○
Lower profile extended ramps		○	○	○	○

Drive-On Standard/Optional Lift Features

FEATURE	Standard Feature ● Optional Feature ○	SM30 30,000 lbs.	4000HDL 40,000 lbs.	HDC50/60 50,000 lbs. / 60,000 lbs.
ALI Certified		●	N/A	●
Open front or open rear design		Closed front	Closed front	Closed front
Recessed installation		N/A	○	N/A
SHOCKWAVE™ Equipped models		N/A	N/A	N/A
Power unit on front column		N/A	N/A	All floor posts
Single point lock release		●	●	●
Cylinder located under the runway		●	Located in columns	Located in columns
Dual function Sentinel Lock™ System		●	N/A	N/A
Air filter / regulator / lubricator		○	○	N/A
Air / Electric utility box		○	○	N/A
Multiple runway lengths available		○	N/A	○
Adjustable runway widths		N/A	●	N/A
Adjustable locking latch bars		●	N/A	N/A
One piece runway		N/A	N/A	●
Internal airline kit		●	N/A	○
Rolling jacks available		○	○	○
Converts to alignment lift		○	Two wheel alignment only	N/A
Drive-thru conversion		○	○	○
Lower profile extended ramps		○	○	○